

**BILL OF MATERIAL**

ADV. MILL #	DATE	LAYOUT	HEAT NO.	MARK	AMT.	SECTION	LENGTH	REMARKS
24				73A	1	ONE BEAM		
				73A	1	W24x131	19-5 1/2	ROE A992
				p15	4	PL 3x5	1-0	A36
				p14	4	PL 3x5	9	A36
				p358	1	PL 1/2x6 3/4	9-0 1/2	BENT A36
				p304	4	PL 1/2x4	4	A36
						FIELD BOLTS		
						4 7/8 Dia A325SC	2 1/4	+1HD WASH

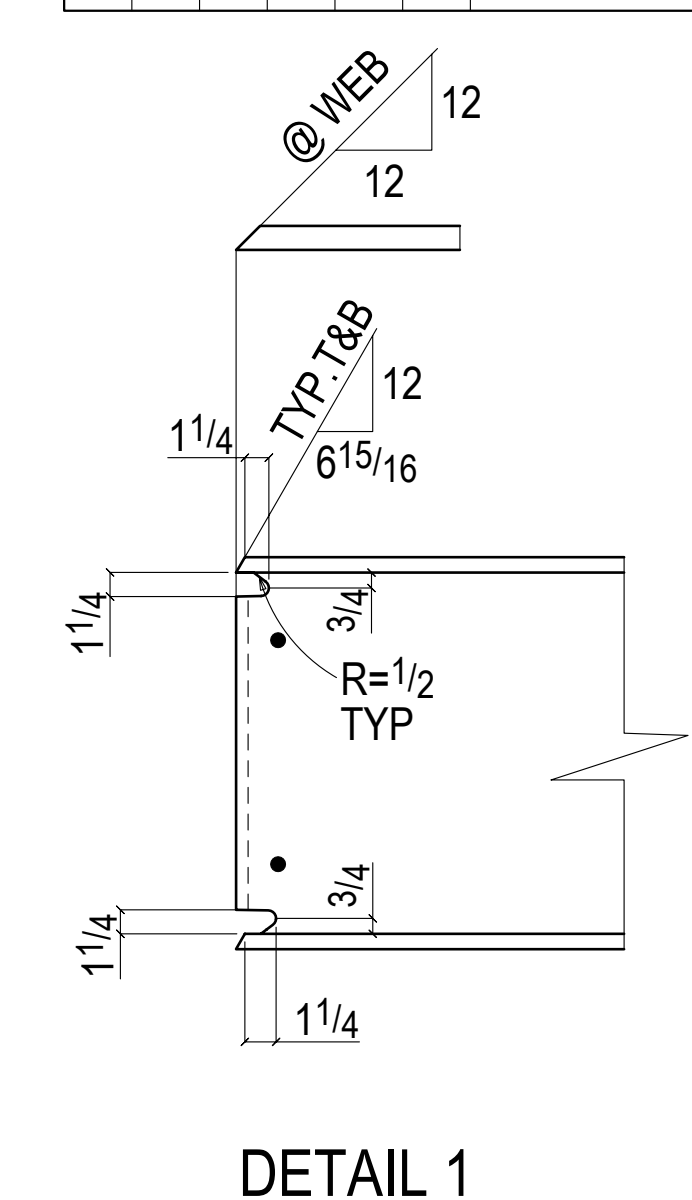
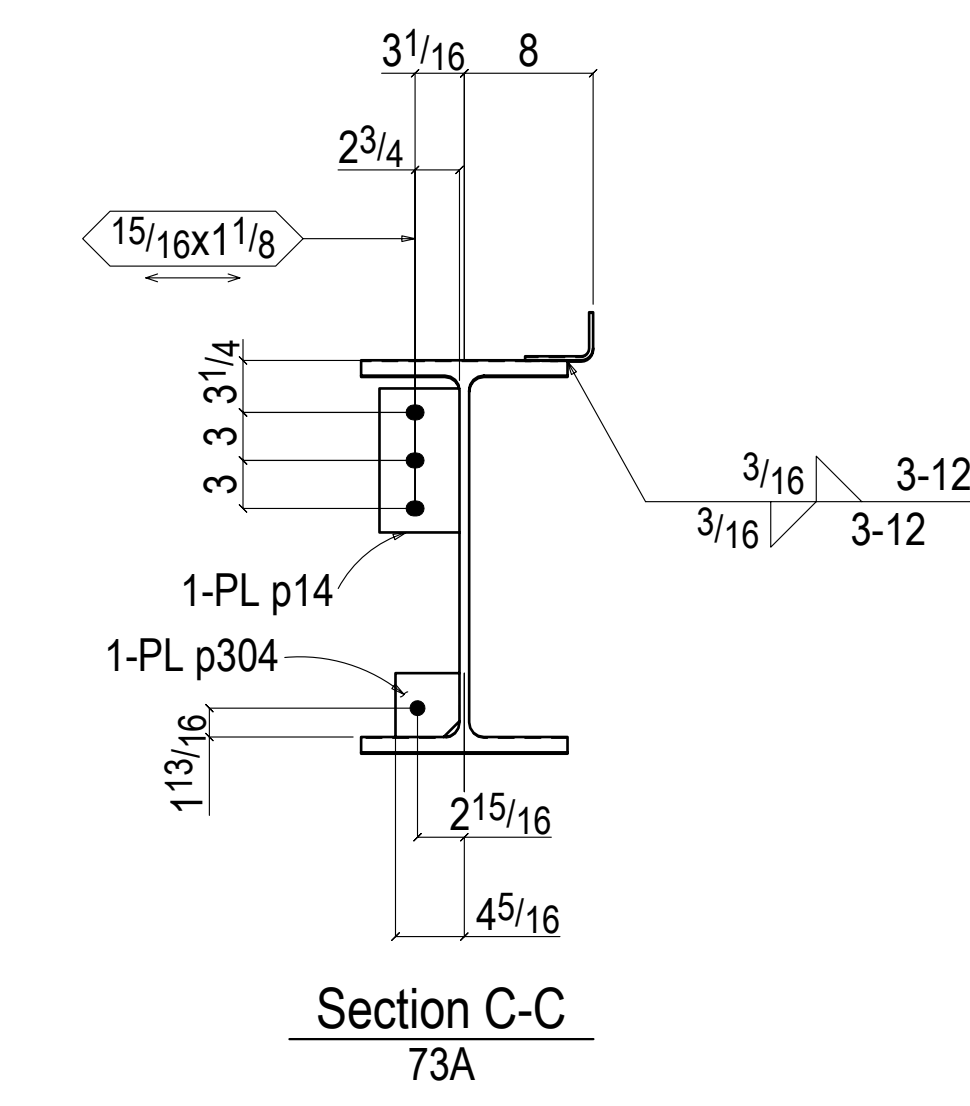
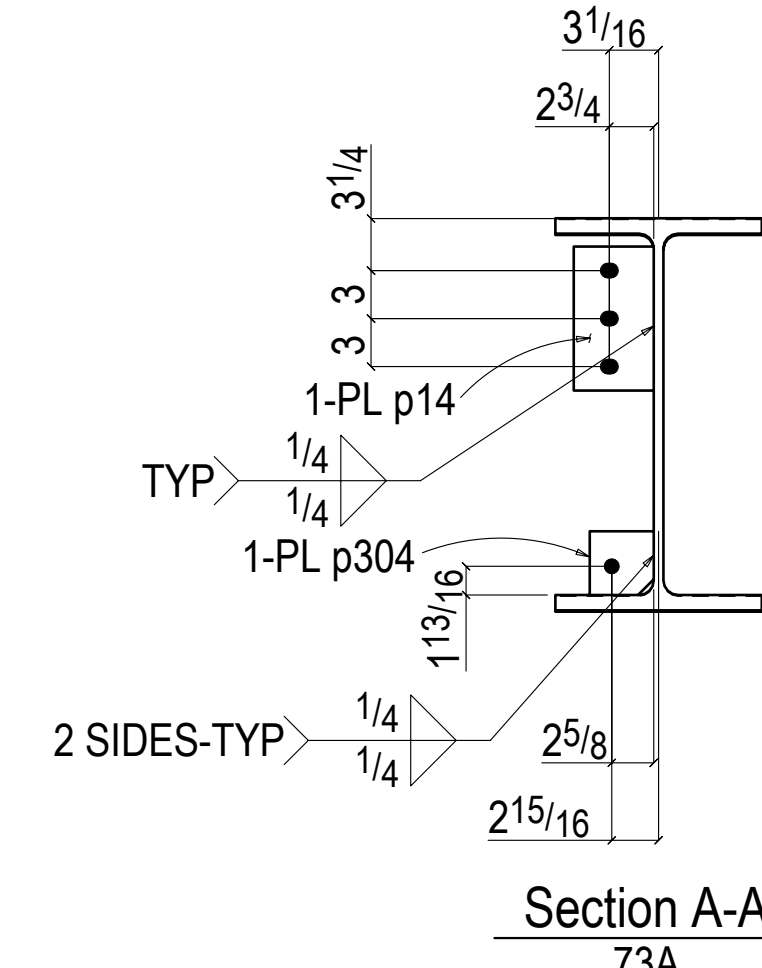
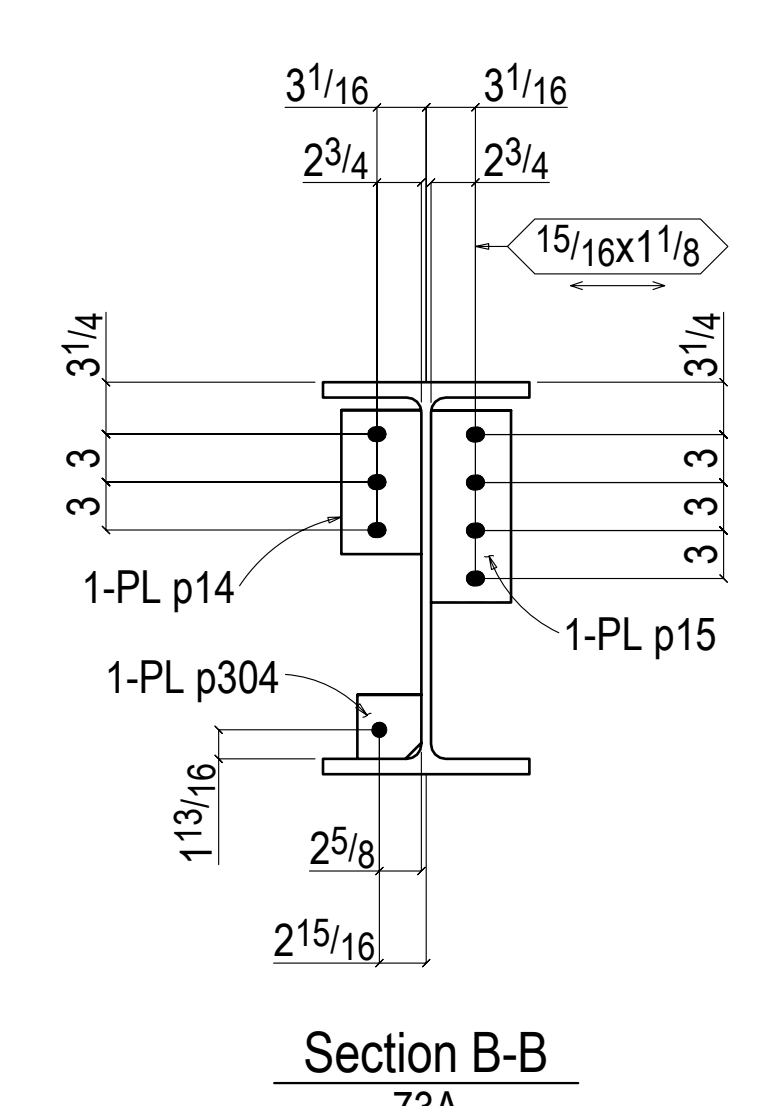
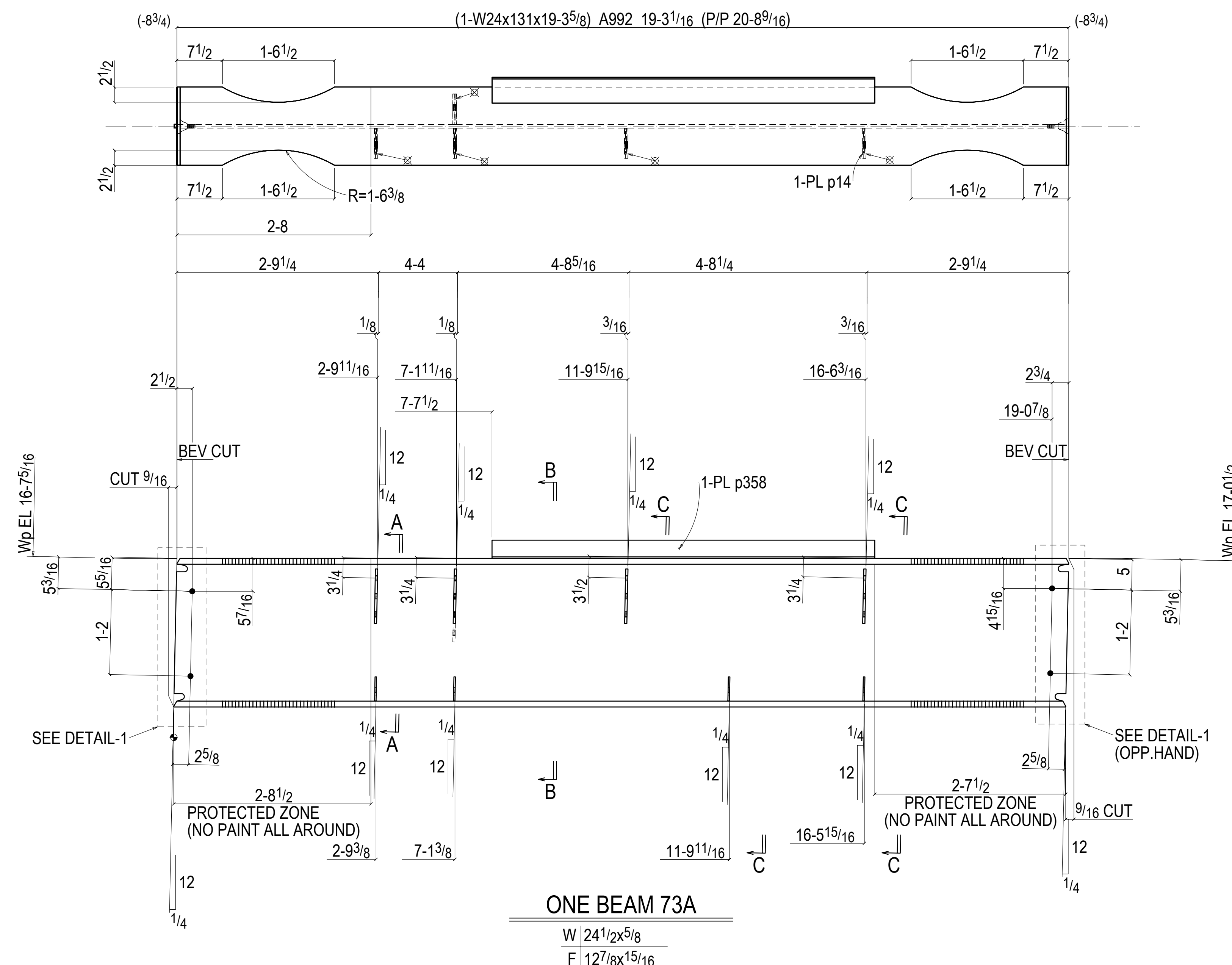

PROJECT:	QUARTZ HILL PUBLIC LIBRARY		
LOCATION:	QUARTZ HILL, CA 93536		
DESCRIPTION:	BEAM DETAIL		
ARCHT:	SVA	CONTRACTOR	GRIFFIN SWINERTON
ENG.:	T. ALBER CHEN (THORNTON TOMASETTI, INC)		
JOB NO.	1524	SHEET NO.	73
		DATE:	07-06-15
		BY:	PDC

SS02.v733