

BILL OF MATERIAL									
ADV	DATE	LAYOUT	HEAT	MARK	AMT.	SECTION	LENGTH	REMARKS	
1-8				10A	1	ONE COLUMN			
				10A	1	W14x283	17'-5 1/16"	SITE A992	
				p395	4	PL 1/2x12	1'-0 1/16"	A36	
				p262	1	PL 1/2x8	1'-0 1/16"	A36	
				f32	1	FL 3/2x4 1/2	1'-4"	A36	
				p141	1	PL 3/8x12 1/2	1'-0 1/16"	A36	
				p219	1	PL 3/8x6	1'-8"	A36	
				p14	1	PL 3/8x5	9"	A36	

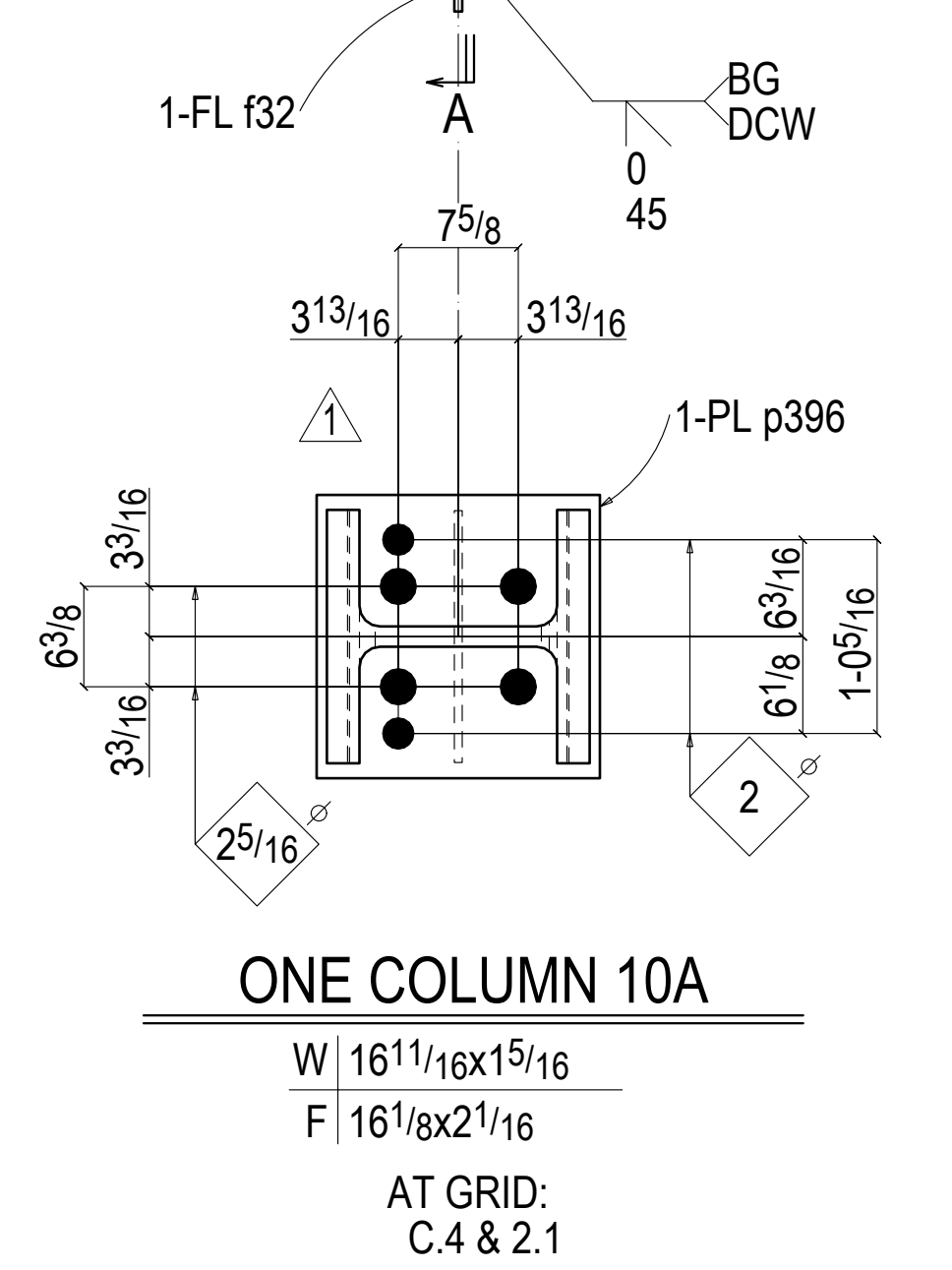
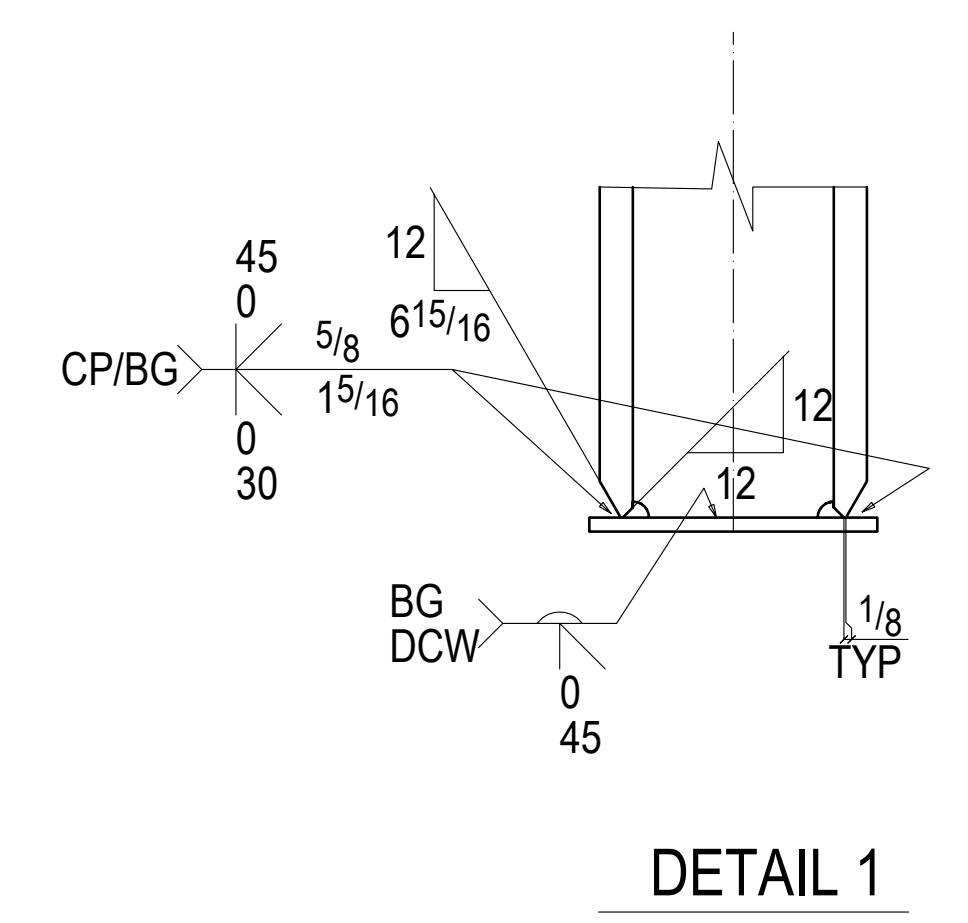
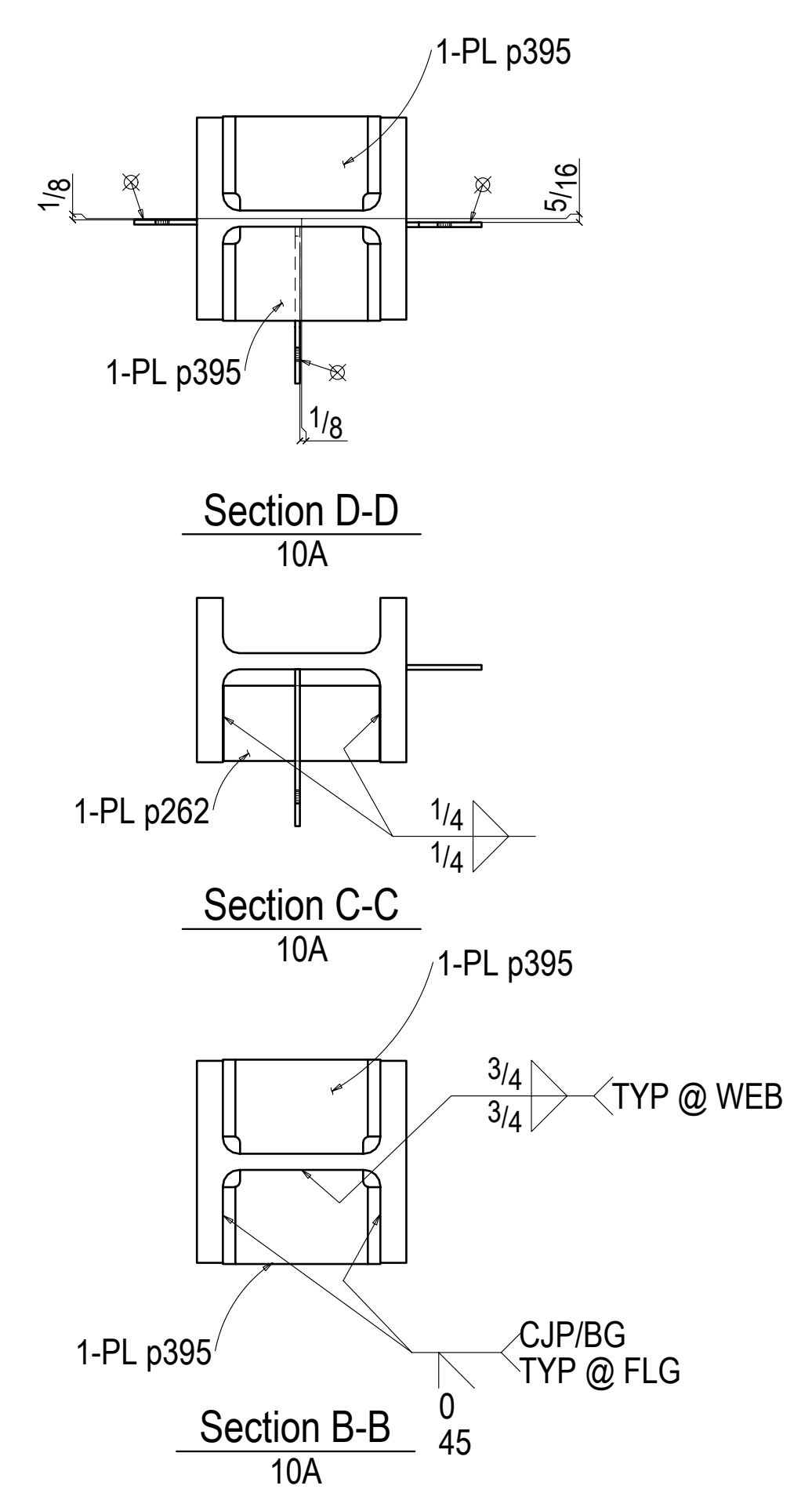
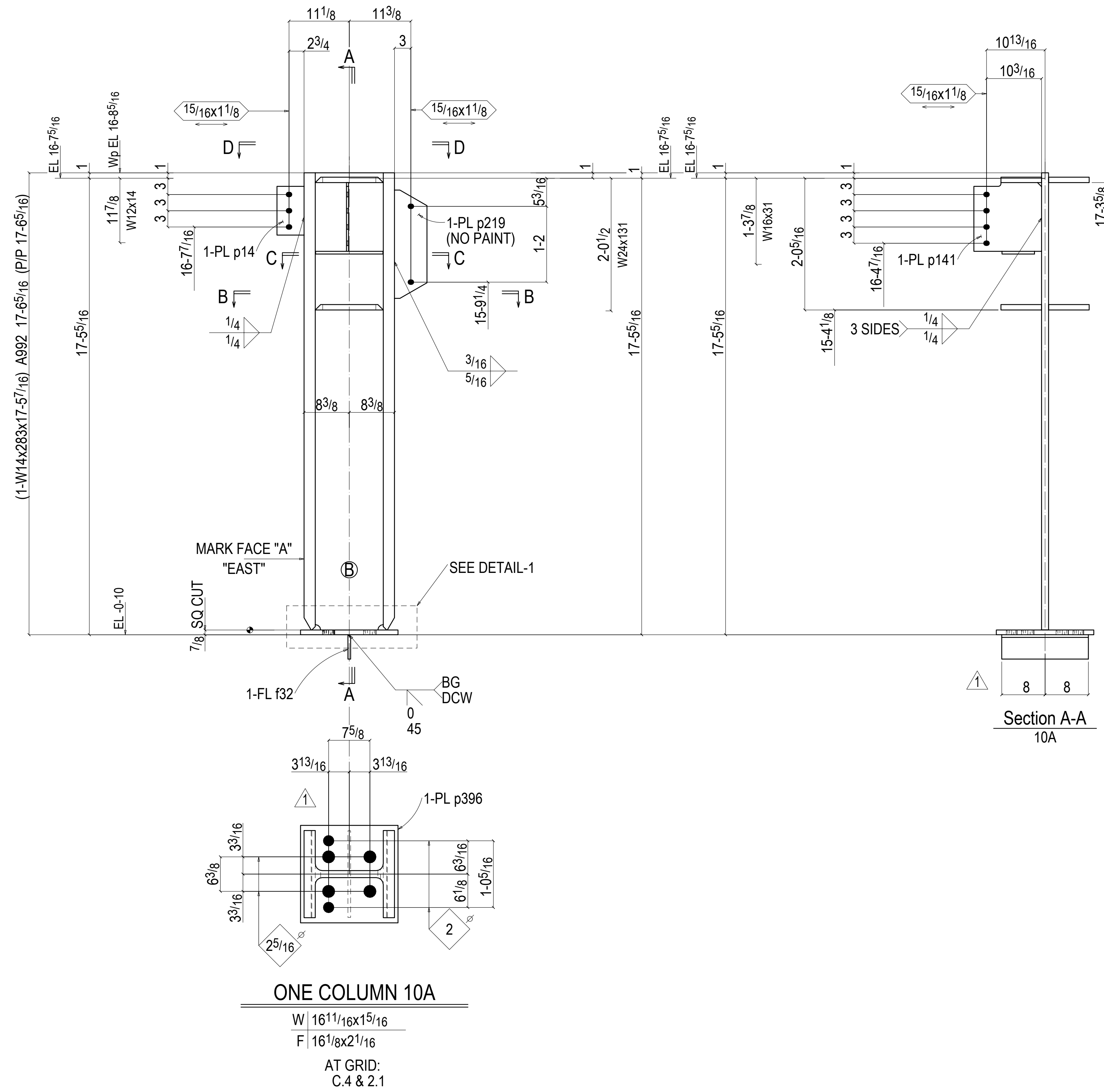

PROJECT:	QUARTZ HILL PUBLIC LIBRARY		
LOCATION:	QUARTZ HILL, CA 93536		
DESCRIPTION:	COLUMN DETAIL		
ARCHT:	SVA	CONTRACTOR	GRIFFIN SWINERTON
ENG.:	T. ALBER CHEN (THORNTON TOMASETTI, INC)		
JOB NO.	1524	SHEET NO.	10
		DATE:	07-06-15
		BY:	PDC